

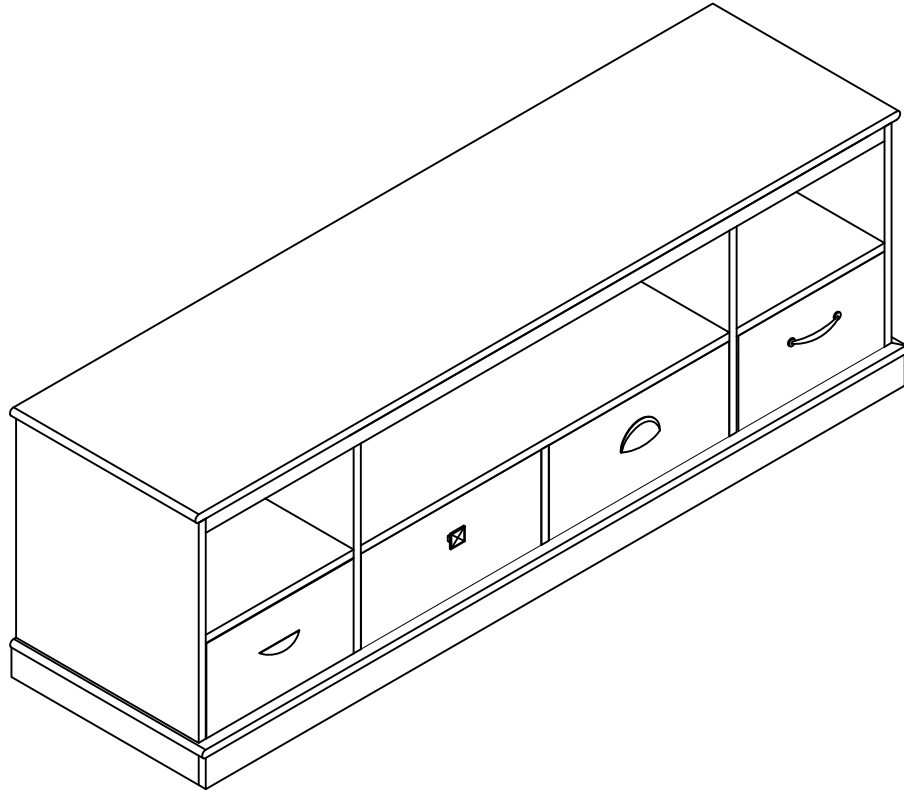

1773096



THIS INSTRUCTION BOOKLET CONTAINS **IMPORTANT** SAFETY INFORMATION. PLEASE READ AND KEEP FOR FUTURE REFERENCE.

ESTE FOLLETO DE INSTRUCCION CONTIENE INFORMACION **IMPORTANTE** DE SEGURIDAD. POR FAVOR LEA Y GUARDE PARA REFERENCIA FUTURA.

CE LIVRET D'INSTRUCTIONS CONTIENT DES INFORMATIONS **IMPORTANTES** SUR LA SÉCURITÉ. S.V.P. LIRE ET CONSERVER POUR RÉFÉRENCE FUTURE.



DO NOT RETURN PRODUCT TO THE STORE
Individual stores do not stock parts.

NO DEVUELVA ESTE PRODUCTO A LA TIENDA
Las tiendas no almacenan partes.

NE PAS RETOURNER LE PRODUIT AU MAGASIN.
Les magasins individuels ne tiennent pas les pièces en inventaire.

Lot Number / Número de Lote / Numéro de lot: _____

Date Of Purchase / Fecha de Compra / Date d'achat: ____ / ____ / ____

If a part is missing or damaged, call our toll-free customer service line. We will gladly ship your replacement parts FREE of charge.

Si faltan partes o piezas, o éstas están dañadas, llame gratis al teléfono de servicio al cliente. Con gusto le enviaremos las partes sin cargo alguno.

Si une pièce est manquante ou endommagée, appelez sans frais notre ligne du service à la clientèle. Il nous fera plaisir de vous expédier les pièces de remplacement GRATUITEMENT.

Need Parts or Assistance?
Necesitas partes o asistencia?
Besoin de pièces ou d'assistance?

1-800-489-3351

or access our website:
o visite nuestra página de internet:
ou visitez notre site Web:

www.altrafurniture.com

For prompt, reliable service please have your assembly manual ready.
Para obtener servicio rápido y confiable, por favor tenga esta manual a la mano.
Pour obtenir un service rapide et fiable, s.v.p. ayez en main votre manuel d'assemblage.

Recommended # of people needed for assembly: 2

El número recomendado de personas necesarias para el montaje: 2

de personnes recommandées pour l'assemblage: 2

B34177309600

Thank you for purchasing from Altra Furniture.
Visit www.altrafurniture.com to view the limited warranty valid in the U.S. and Canada.

Gracias por haber comprado de Altra Furniture.
Visitar www.altrafurniture.com para mirar la garantía limitada válida solamente en U.S.A y Canada.

Merci pour votre achat de produits Altra Furniture.
Visitez www.altrafurniture.com pour voir la garantie limitée valide aux États-Unis et au Canada.

ALTRA FURNITURE CUSTOMER SERVICE

SERVICIO A LA CLIENTE DE ALTRA FURNITURE

SERVICE À LA CLIENTÈLE D'ALTRA FURNITURE

Before starting - Antes de empezar - Avant de débiter .

- Read each step carefully before starting. It is very important that each step of instruction is performed in the correct order. If these steps are not followed in sequence, assembly difficulties will occur.
Leer con cuidado cada paso antes de empezar. Es muy importante de ejecutar cada paso en el orden correcto. Si los pasos no están ejecutados en secuencia, ocurrirá dificultades en el montaje.
Lisez attentivement chaque étape avant de commencer. Il est très important que chaque étape d'instruction soit effectuée dans l'ordre indiqué. Si ces étapes ne sont pas suivies dans l'ordre, des difficultés d'assemblage se produiront.
- Make sure all parts are included. Most board parts are labeled or stamped on the raw edge.
Asegurar que todas las piezas son incluidas. La mayoría de las tablas tienen las etiquetas o los sellos en el lado sin acabado.
Assurez-vous que toutes les pièces sont incluses. La plupart des panneaux sont étiquetés ou estampés sur le bord non fini.
- Work in spacious area, preferably on a carpet, near the place the unit will be used.
Trabajar en una área espaciosa, preferible sobre alfombra, cercas del lugar donde se va a usar el mueble.
Travaillez dans un endroit spacieux, préférentiellement sur un tapis, à proximité de l'endroit où le meuble sera utilisé.
- Have the following tools close at hand.
Tener las herramientas siguientes cerca de la mano.
Ayez à portée de la main, les outils suivants.
- Do not use power tools to assemble your furniture. Power tools may strip or damage the parts.
No use herramienta eléctrica para montar su unidad. Las herramientas eléctricas pueden dañar las piezas.
Ne pas utiliser d'outils électriques pour assembler votre mobilier. Les outils électriques peuvent briser ou endommager les pièces.

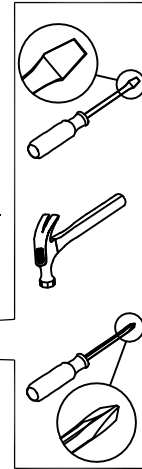

Call us at: **1-800-489-3351**
Llamar a: (in U.S.A. only)
Appelez-nous au: (Solo en U.S.A)
(aux États-Unis seulement)



Fax: **1-636-745-1005**

TÉLÉCOPIEUR:

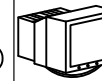

Visit our Website:
Visitar nuestro website: www.altrafurniture.com
Visitez notre site Web:



Write to: ALTRA FURNITURE
Escribir a: 410 East 1st Street South Wright City,
Écrivez à: MO 63390 USA
Attn: Service Dept.

Monday - Friday
9:00 am - 5:00 pm
Central Time

Lunes - Viernes
9:00h - 17:00h
Tiempo Central

Lundi - Vendredi
9h00 - 17h00
Heure du centre

HELPFUL HINTS

- Visit our website for assembly video clips.
- Identify, sort and count the parts before attempting assembly.
- Call our toll free number if you need assistance identifying parts.
- Compression dowels are tapped in with a hammer.
- Slides have lips only on the right side.
- Cam locks that are properly fastened on a horizontal board will face toward the center of the unit, on a vertical board the point on the lock will face the bottom.
- Back panels provide stability and support. Use all the nails provided.
- When tapping nails into a board, be sure there are equal margins on all sides to square the unit.
- Units without the back panel installed may collapse.
- Clean the product with your favorite furniture polish and a soft cloth. DO NOT USE harsh chemicals or abrasive cleaners.
- Move your new furniture carefully, with two people lift and carry the unit to its new location.
- Never push, drag or scoot your furniture (especially on carpet).
- Your furniture can be disassembled and reassembled to move.
- Additional parts are available for a nominal fee.

NOTES UTILES

- Visitar nuestro website para mirar los videos cortos del montaje.
- Identificar, clasificar y contar las piezas antes de intentar el montaje.
- Llamar gratis a nuestro número de servicio si necesita ayuda con identificar las piezas.
- Las clavijas de compresión se taladrarán con un martillo.
- Las correderas sólo tienen las protrusiones en el lado derecho.
- Las cerraduras de leva que se atan propiamente en una tabla horizontal se puntan al centro de la unidad, y las en una tabla vertical se puntan al fondo.
- Los paneles traseros se mantienen la estabilidad. Usar todos los tornillos proporcionados.
- Al taladrar los tornillos en una tabla, asegurarse que hay márgenes iguales en todos los lados para cuadrar la unidad.
- Las unidades sin panel trasero pueden derrumbarse.
- Limpiar la unidad con su pulimento favorito de mueble y una tela suave. NO UTILIZAR productos con químicos duros o abrasivos.
- Mover su mueble nuevo cuidadosamente, con dos personas levantar la unidad a su nuevo lugar.
- Nunca empujar o arrastrar su mueble (especialmente en alfombra).
- Poderse desmontar y volver a montar su mueble de para mover.
- Piezas adicionales están disponibles para una cuota nominal.

CONSEILS UTILES

- Visitez notre site Web pour visionner des vidéos d'assemblage.
- Identifiez, triez et compter les pièces avant d'entreprendre l'assemblage.
- Appelez notre numéro sans frais si vous avez besoin d'aide pour identifier les pièces.
- Les goujons de compression sont enfoncés en frappant avec un marteau.
- Les glissières ont un rebord sur le côté droit seulement.
- Les serrures de came qui sont fixées correctement sur un panneau horizontal seront orientées vers le centre du meuble, sur un panneau vertical, la pointe de la serrure sera orientée vers le bas.
- Les panneaux arrière assurent la stabilité et le soutien. Utilisez tous les clous fournis.
- Lorsque vous frappez les clous dans le panneau, assurez-vous qu'ils sont à distance égale sur tous les côtés pour bien cadrer le meuble.
- Les meubles sans panneau arrière installé peuvent s'effondrer.
- Nettoyez le meuble avant votre poli à meubles préféré et un chiffon doux. NE PAS UTILISER de produits chimiques forts ou de nettoyeurs abrasifs.
- Déplacez délicatement votre nouveau meuble, avec deux personnes pour soulever et transporter le meuble à son nouvel emplacement.
- Ne jamais pousser, traîner ou tirer votre meuble (surtout sur un tapis).
- Votre meuble peut être démonté et réassemblé pour le déplacer.
- Des pièces supplémentaires sont disponibles pour un prix modique.

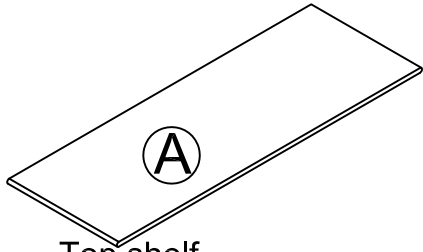

Top shelf
Estante superior
Étagère supérieure
T1773096010

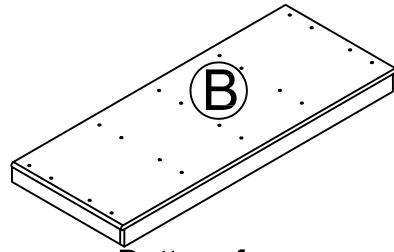

Bottom frame
Marco inferior
Cadre inférieur
T1773096020

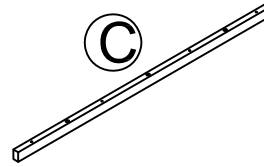

Top shelf apron
Embellecedor para estante superior
Ceinture étagère supérieure
T1773096030

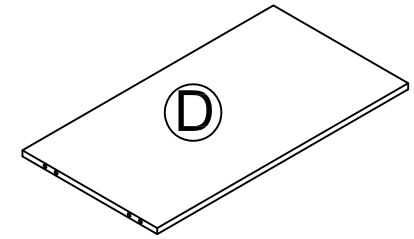

Center fixed shelf
Estante fijo central
Tablette centrale fixe
T1773096040

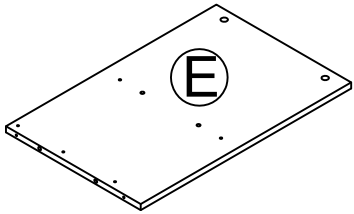

Left side panel
Panel izquierdo
Panneau gauche
T1773096050

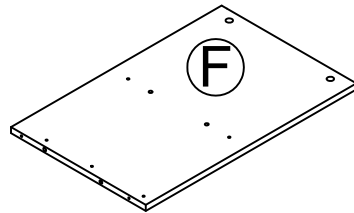

Right side panel
Panel derecho
Panneau droit
T177306060

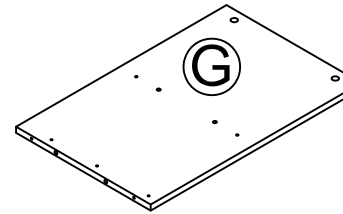

Left partition
Partición izquierda
Cloison gauche
T1773096070

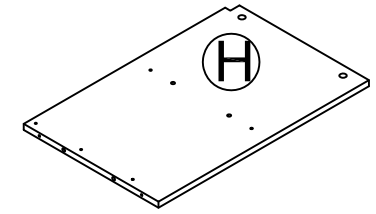

Right partition
Partición derecha
Cloison droite
T1773096080

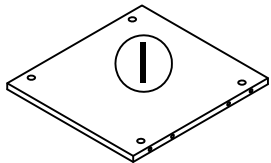

Fixed shelf (2)
Estante fijo (2)
Tablette fixe (2)
T1773096090

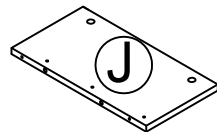

Partition
Partición
Cloison
T1773096100

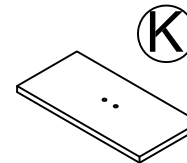

Drawer front
Panel Frontal de Cajón
Façade de tiroir
T1773096110

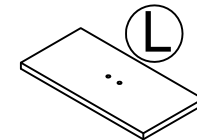

Drawer front
Panel Frontal de Cajón
Façade de tiroir
T1773096120

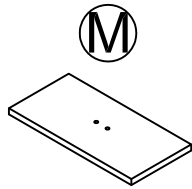

Drawer front
Panel Frontal de Cajón
Façade de tiroir
T1773096130

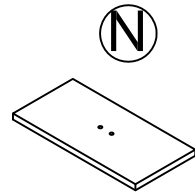

Drawer front
Panel Frontal de Cajón
Façade de tiroir
T1773096140

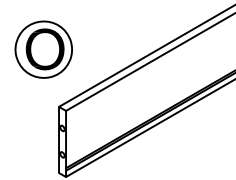

Drawer left side panel (4)
Panel Izquierdo de Cajón (4)
Panneau gauche de tiroir (4)
T1773096150

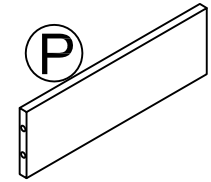

Drawer right side panel (4)
Panel Derecho de Cajón (4)
Panneau droit de tiroir (4)
T1773096160

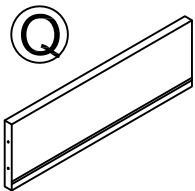

Drawer back panel (4)
Panel Trasero de Cajón (4)
Panneau arrière de tiroir (4)
T1773096170

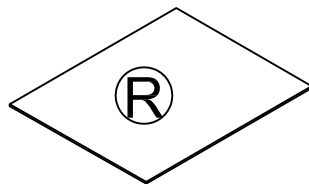

Drawer bottom (4)
Fondo de Cajón (4)
Fond de tiroir (4)
T1773096180

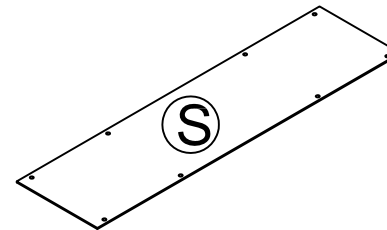

Back panel
Panel trasero
Panneau arrière
T1773096190

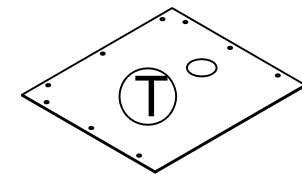

Back panel (2)
Panel trasero (2)
Panneau arrière (2)
T1773096200

PARTS -PIEZAS - PIÈCES



Ø6 x 35 mm

1

x 38

Cam bolt
Perno de la leva
Boulon de came
TWQ0011



Ø15 x 11 mm

2

x 22

Cam lock
Cerradura de la leva
Serrure de came
TWQ0012



Ø8 x 30 mm

3

x 35

Wooden dowel
Clavija de madera
Goujon en bois
TWQ0003



Ø3 x 15 mm

4

x 28

Screw
Tornillo
Vis
TWQ0009

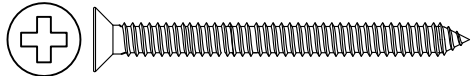

Ø4 x 44mm

5

x 10

Screw
Tornillo
Vis
TWQ0027

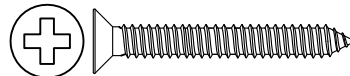

Ø4 x 32 mm

6

x 20

Screw
Tornillo
Vis
TWQ0010



7

x 1

Glue
Pegamento
Colle
TWQ0008



8

x 1

Knob
Puno
Bouton
TWQ0085



9

x 1

Pull
Jalón
Poignée
TWQ0031

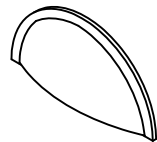

10

x 1

Pull
Jalón
Poignée
TWQ0090



11

x 1

Handle
Manija
Poignée
TWQ0042



Ø9x4x19mm

12

x 6

Screw bolt
Tornillo con tuerca
Vis à boulon
TWQ0060

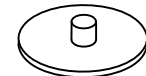

13

x 8

Cam cover
Leva de cubierta
Cache-Came
TWQ0013

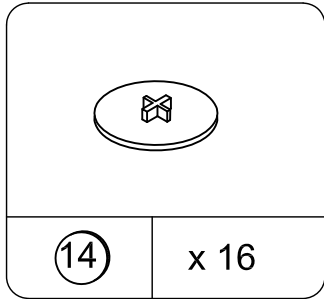

14 x 16

Cam cover
Leva de cubierta
Cache-Came
TWQ0045

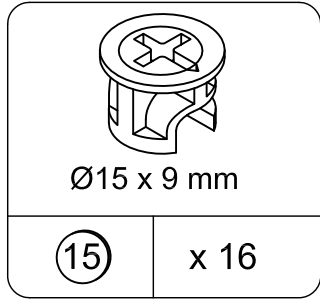

Ø15 x 9 mm

15 x 16

Cam lock
Cerradura de la leva
Serrure de came
TWQ0086

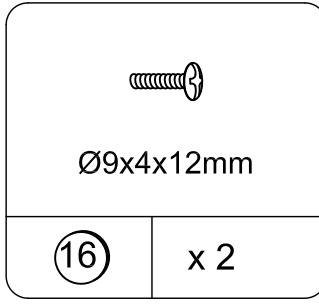

Ø9x4x12mm

16 x 2

Screw bolt
Tornillo con tuerca
Vis à boulo
TWQ0060

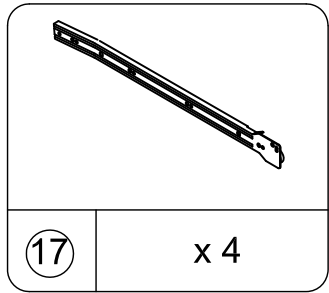

17 x 4

Left cabinet member
Corredera de mueble izquierda
Élément gauche du meuble
TWQ0109

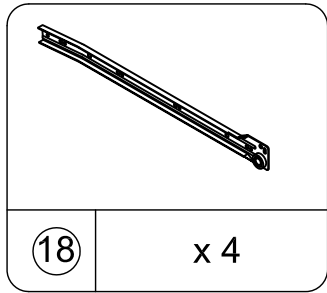

18 x 4

Right cabinet member
Corredera de mueble derecha
Élément droit du meuble
TWQ0110

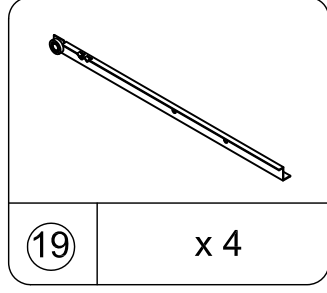

19 x 4

Left drawer runner
Deslizador izquierdo de cajon
Glissière de tiroir gauche
TWQ0111

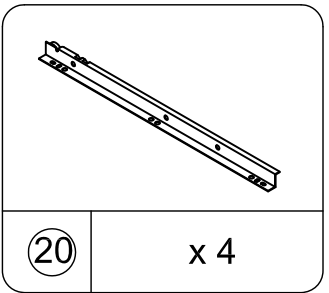

20 x 4

Right drawer runner
Deslizador derecha de cajon
Glissière de tiroir droite
TWQ0112

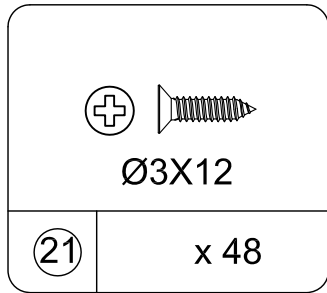

Ø3X12

21 x 48

Screw
Tornillo
Vis
TWQ0088

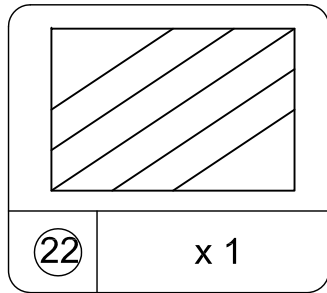

22 x 1

Warning label
Etiqueta de Advertencia
Étiquette d'avertissement
TWQ0113

This illustration shows how the CAM fastening system works.
Esta ilustración muestra como funciona el sistema de fijación de leva.

Cette illustration montre comment le système de fixation de la CAME fonctionne

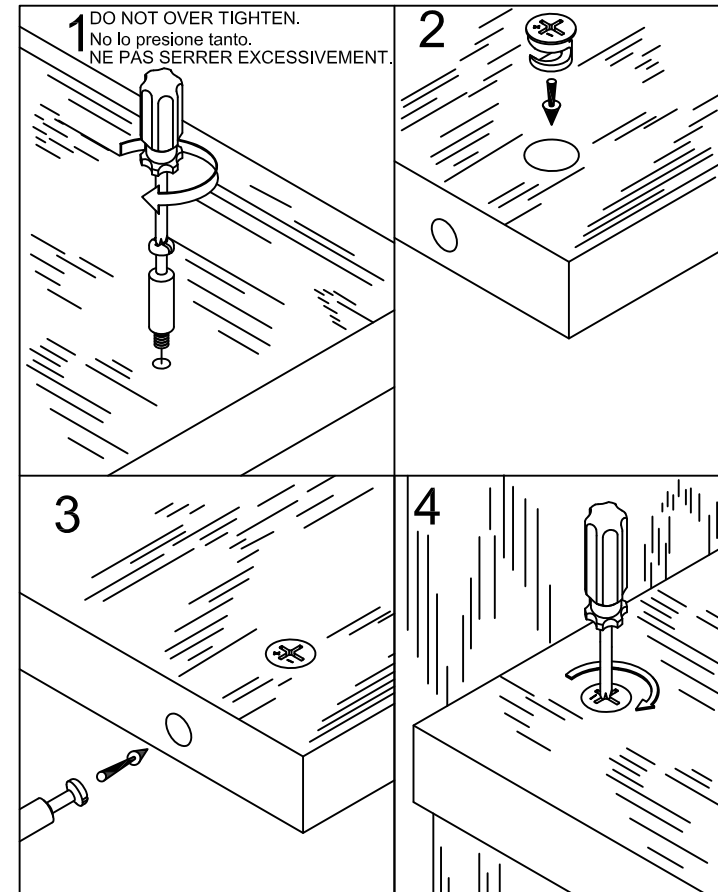

To view a video on how the CAM fastening system works, download a free QR-reader on your smartphone, then scan the code.

Para ver un video de como funciona el sistema de sujeción CAM, descargue una aplicación gratis que podra ver en su teléfono movil, entonces escnee el código.

Pour visionner une vidéo sur la façon dont fonctionne le système de fixation de la CAME, téléchargez notre lecteur QR gratuit sur votre téléphone intelligent, puis numérissez le code.

1

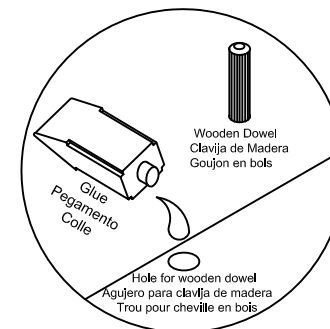
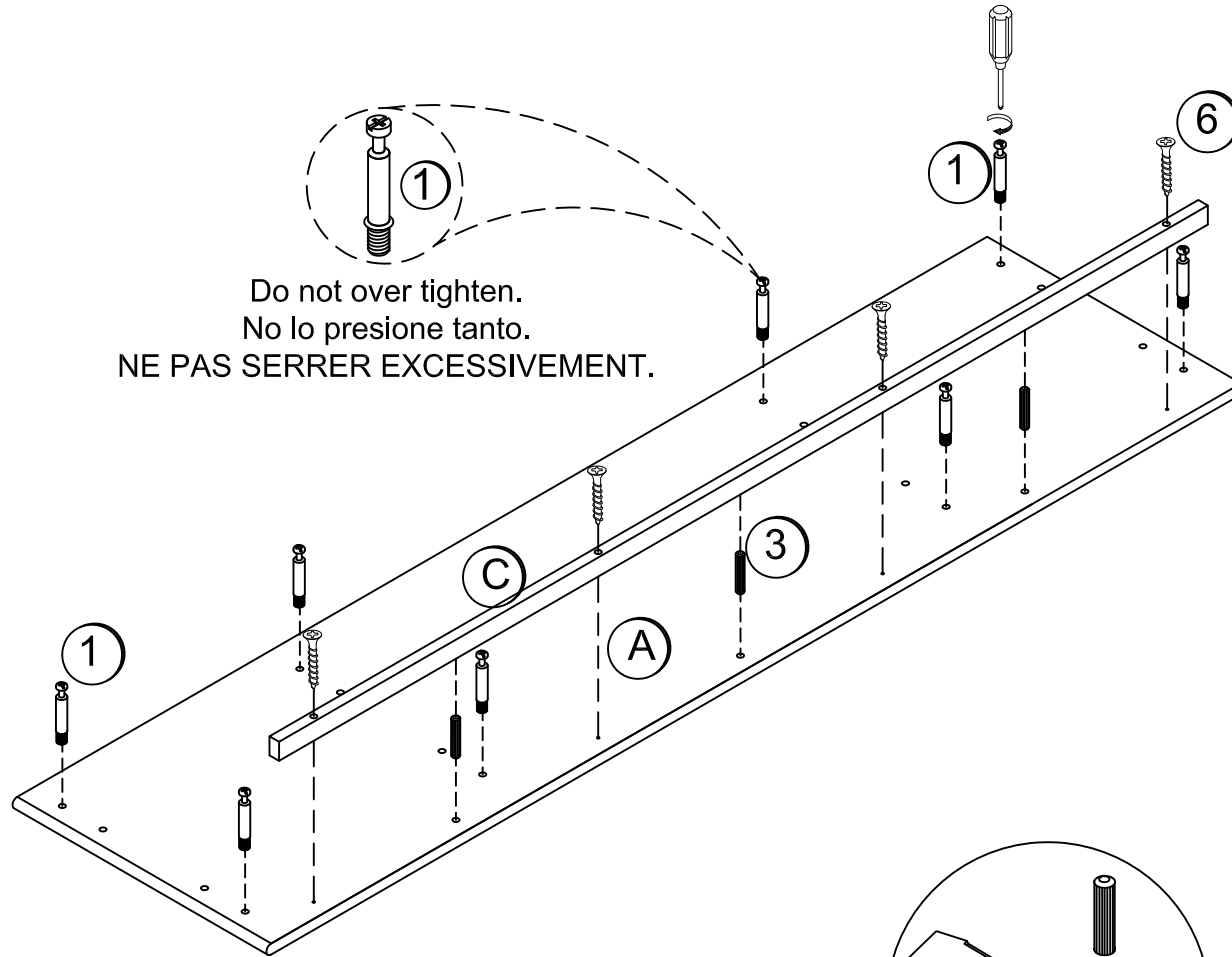
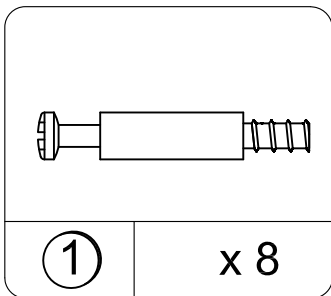
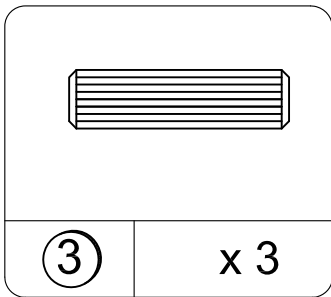
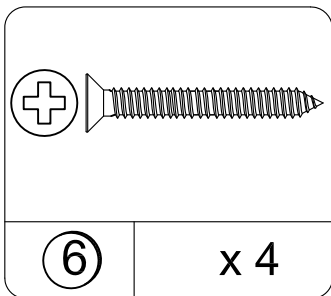

Use one drop of glue in dowel hole.
Use una gota de pegamento en el agujero de clavija.
Utilisez une goutte de colle dans le trou de la cheville

2

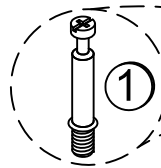

Do not over tighten.
No lo presione tanto.
NE PAS SERRER EXCESSIVEMENT.

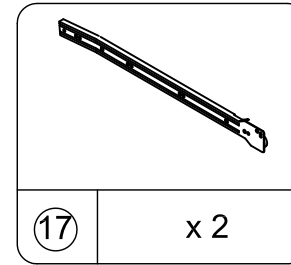

17 x 2

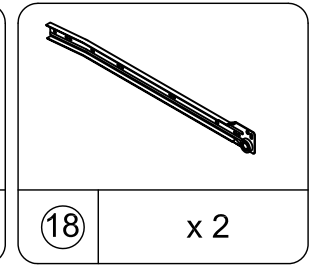

18 x 2

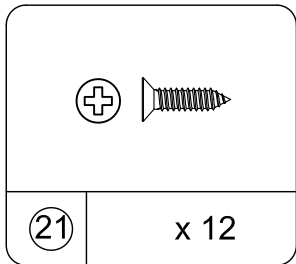

21 x 12

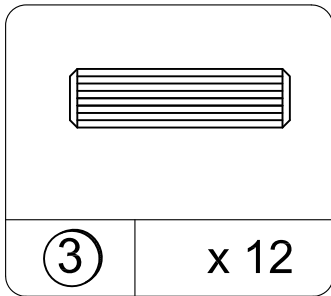

3 x 12

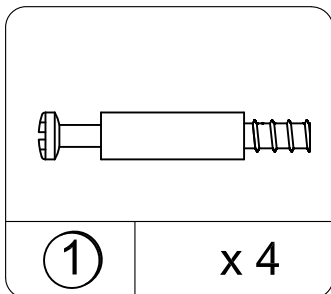

1 x 4

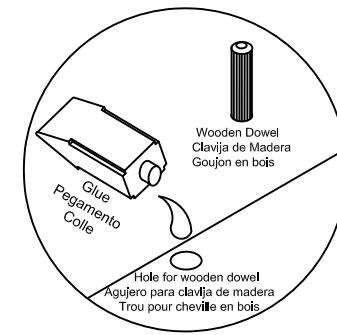
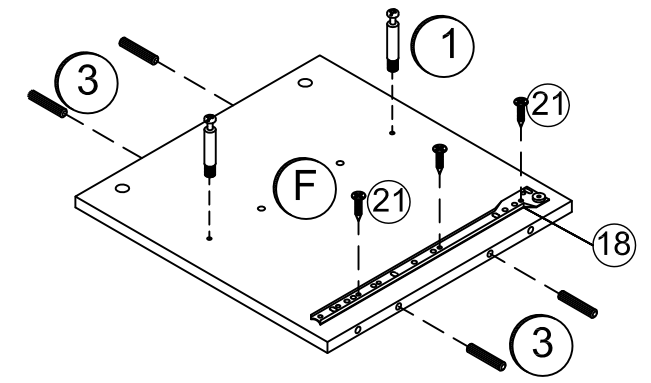
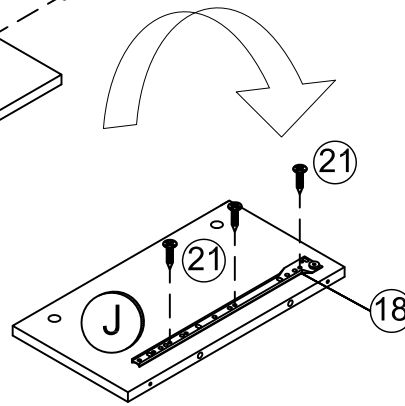
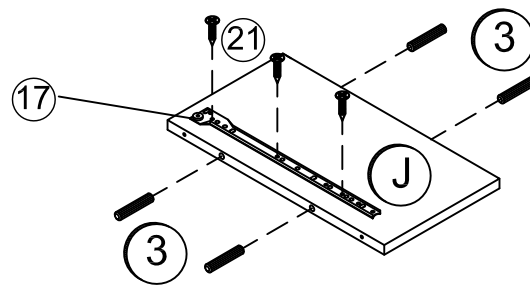
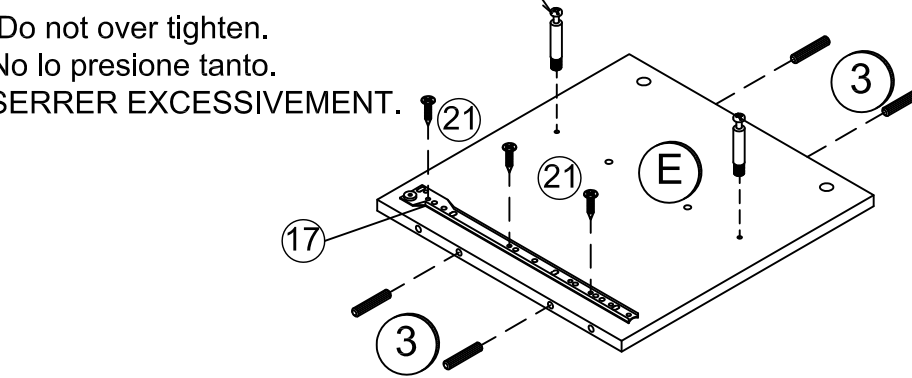

Use one drop of glue in dowel hole.
Use una gota de pegamento en el agujero de clavija.
Utilisez une goutte de colle dans le trou de la cheville

3

Do not over tighten.
No lo presione tanto.

NE PAS SERRER EXCESSIVEMENT.

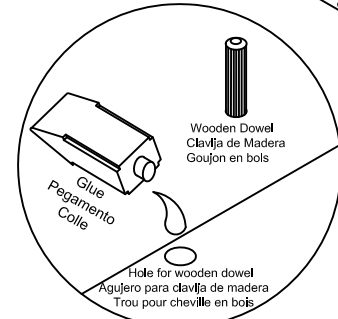
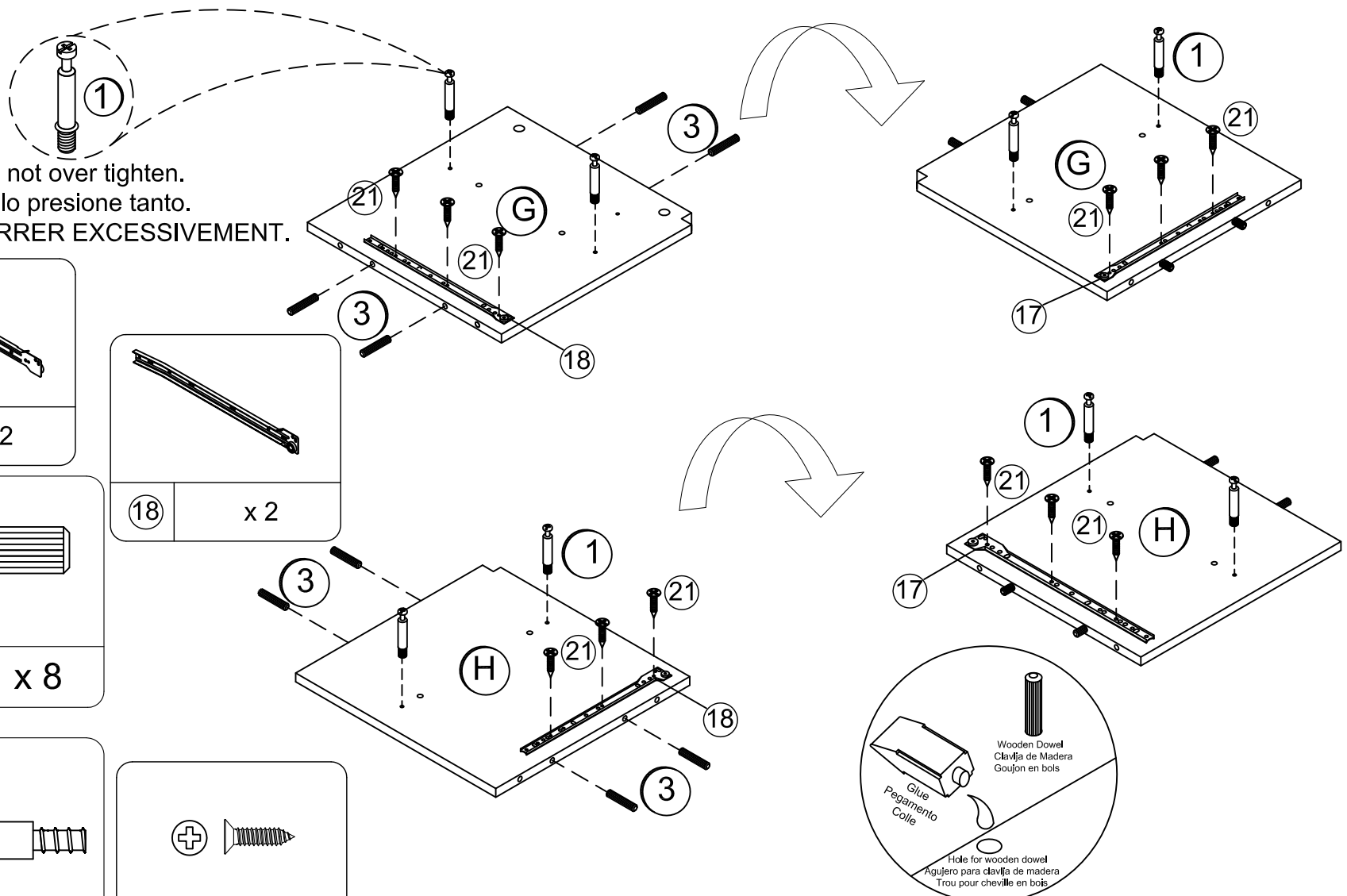
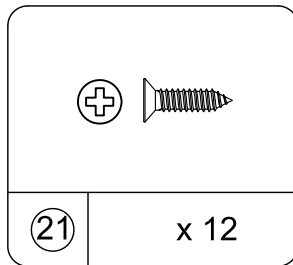
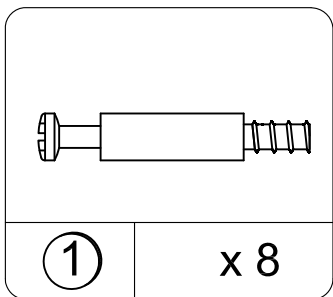
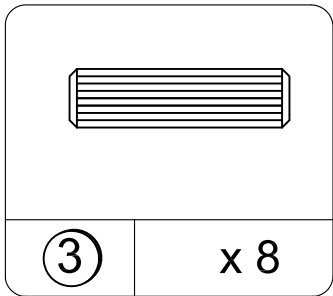
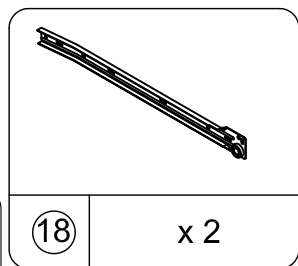
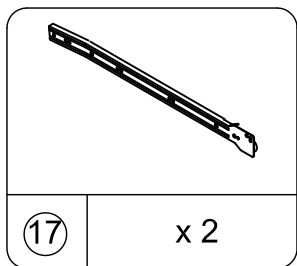

Use one drop of glue in dowel hole.
Use una gota de pegamento en el agujero de clavija.
Utilisez une goutte de colle dans le trou de la cheville

4

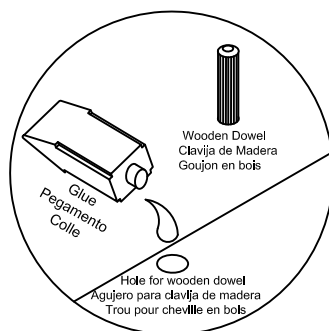
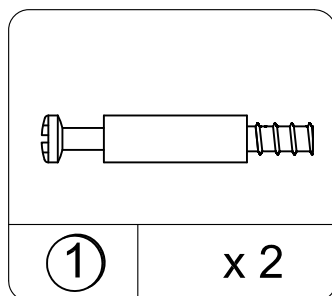
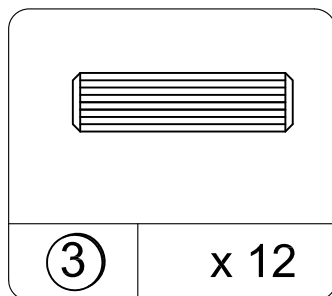
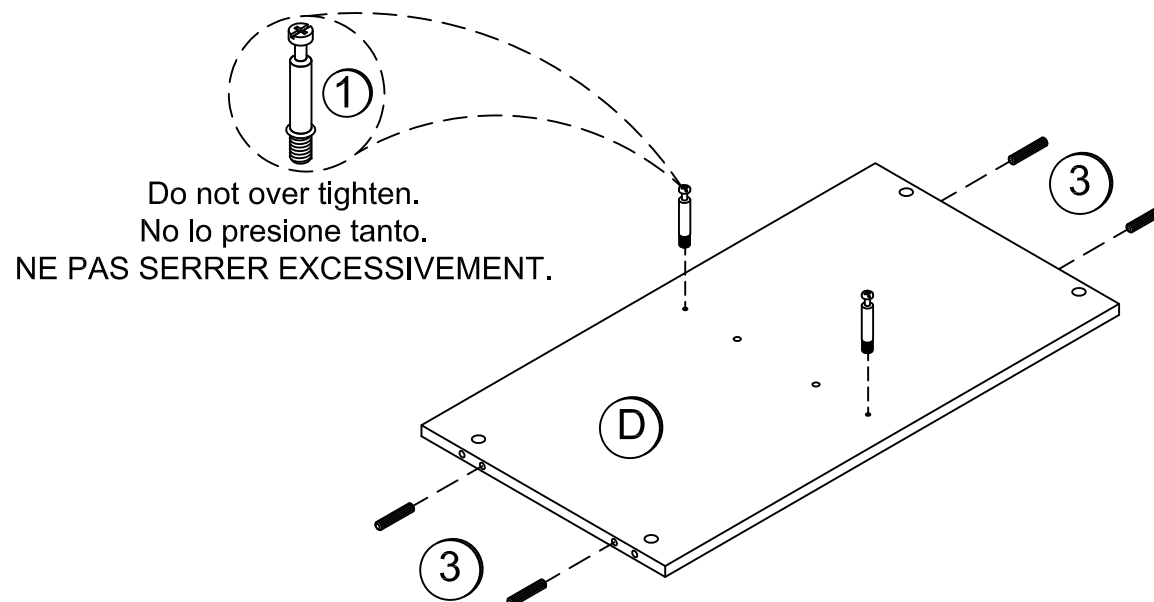

Use one drop of glue in dowel hole.
Use una gota de pegamento en el agujero de clavija.
Utilisez une goutte de colle dans le trou de la cheville

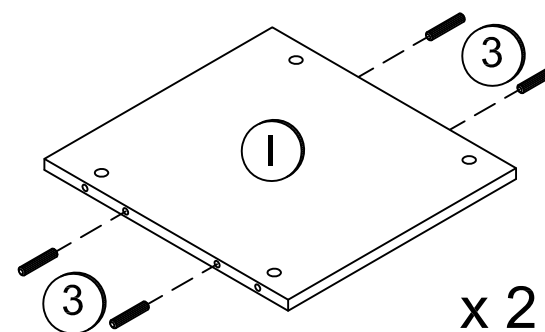

5

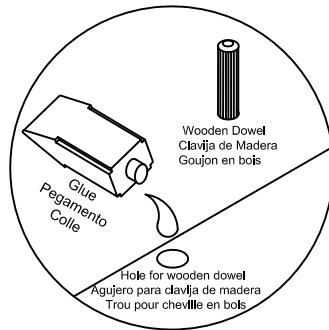

Use one drop of glue in dowel hole.
Use una gota de pegamento en el agujero de clavija.
Utilisez une goutte de colle dans le trou de la cheville

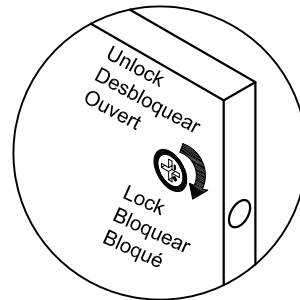
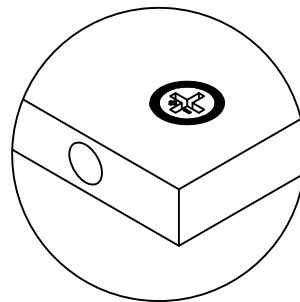
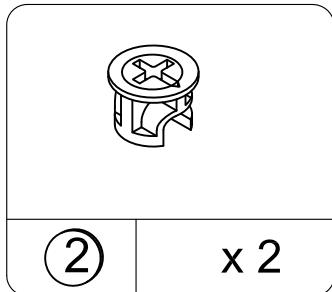
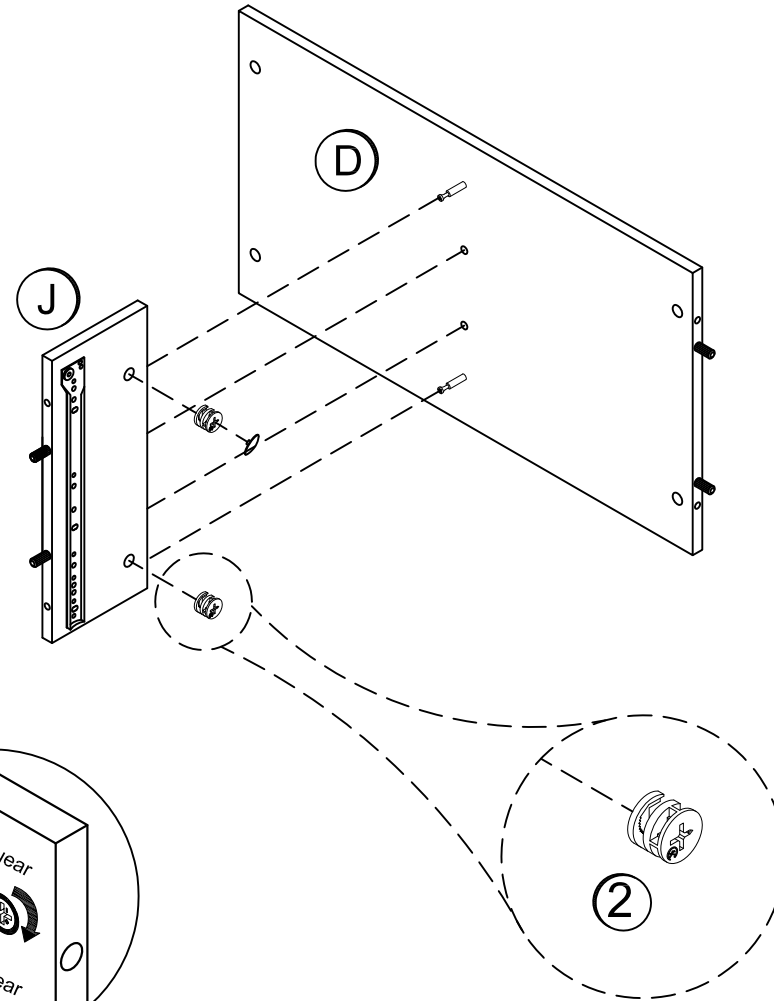

Proper orientation of cam lock
La orientacion apropiada para el seguro de bloqueo
Bonne orientation du dispositif de blocage à came

6

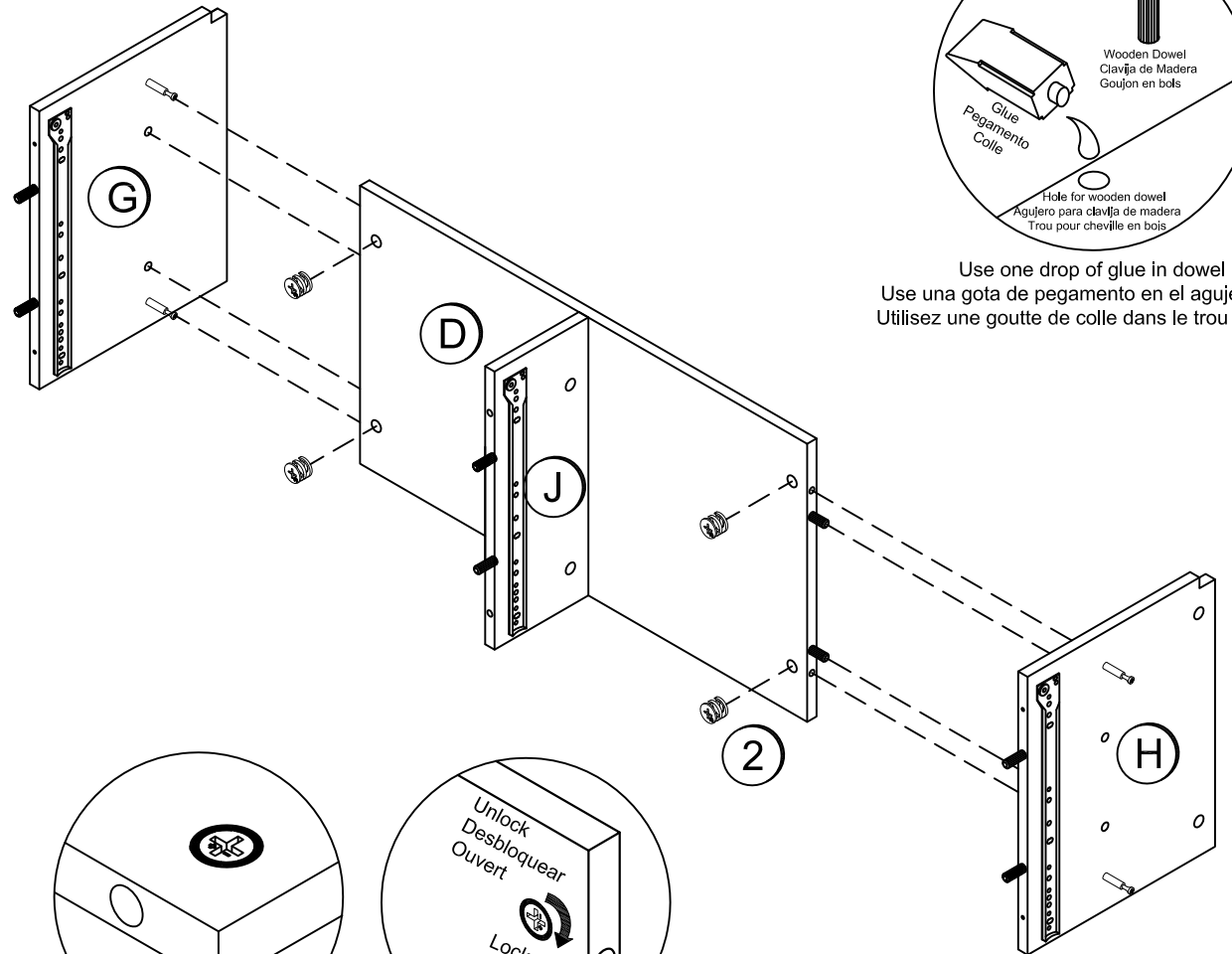

Use one drop of glue in dowel hole.
Use una gota de pegamento en el agujero de clavija.
Utilisez une goutte de colle dans le trou de la cheville

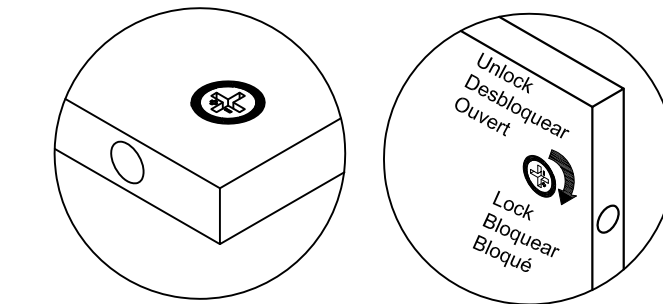
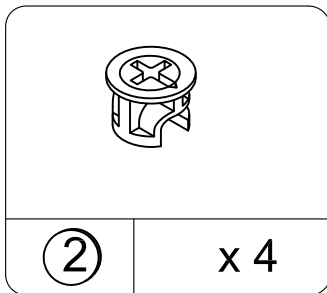

Proper orientation of cam lock
La orientacion apropiada para el seguro de bloqueo
Bonne orientation du dispositif de blocage à came

7

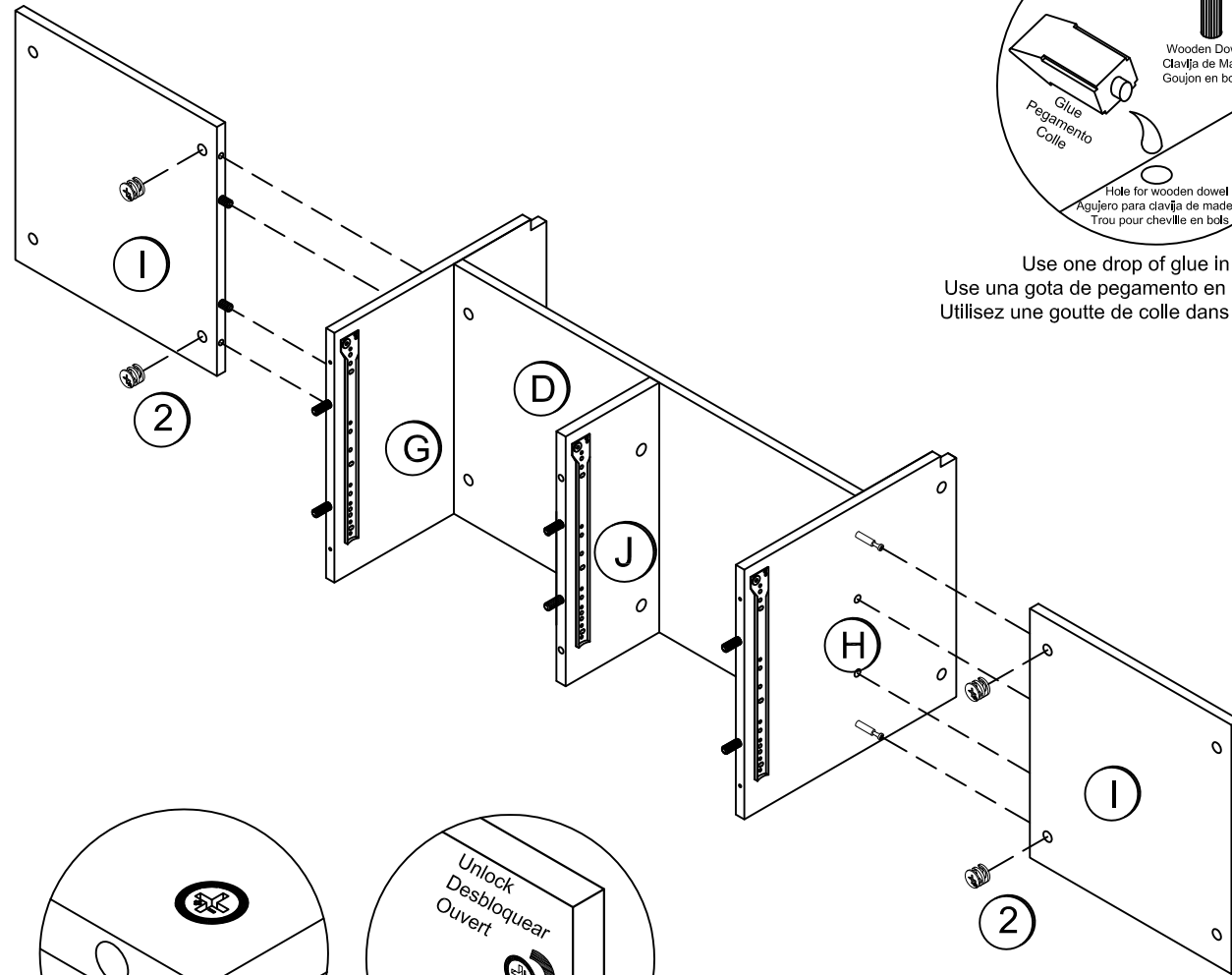

Use one drop of glue in dowel hole.
 Use una gota de pegamento en el agujero de clavija.
 Utilisez une goutte de colle dans le trou de la cheville

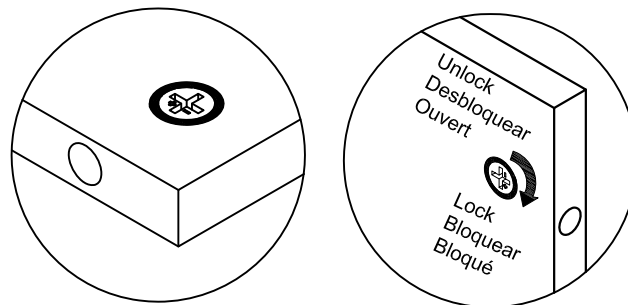
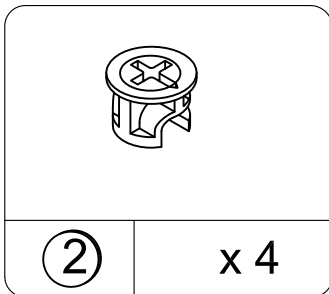

Proper orientation of cam lock
 La orientacion apropiada para el seguro de bloqueo
 Bonne orientation du dispositif de blocage à came

8

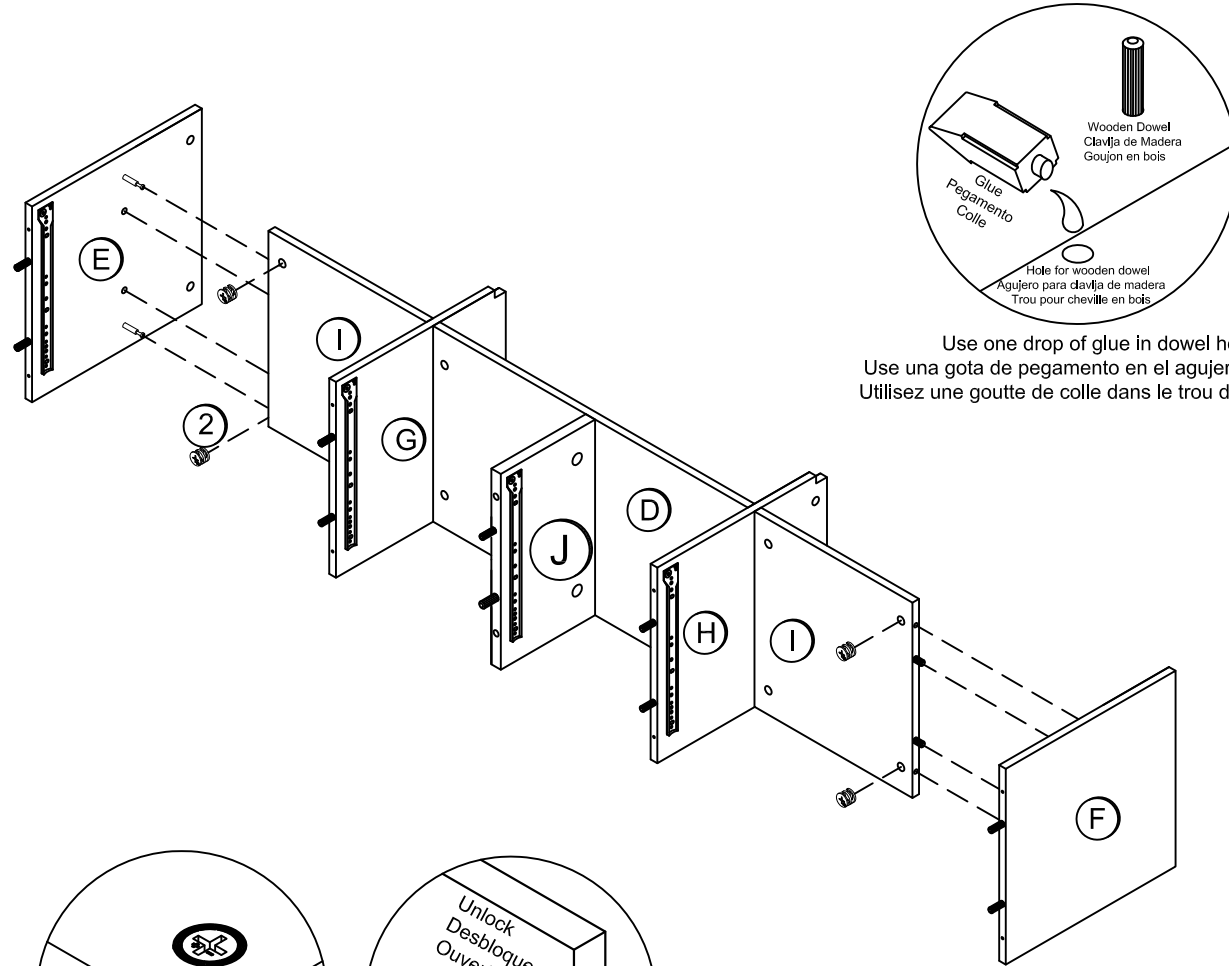

Use one drop of glue in dowel hole.
Use una gota de pegamento en el agujero de clavija.
Utilisez une goutte de colle dans le trou de la cheville

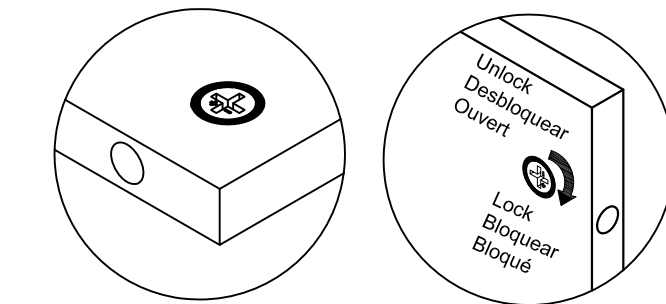
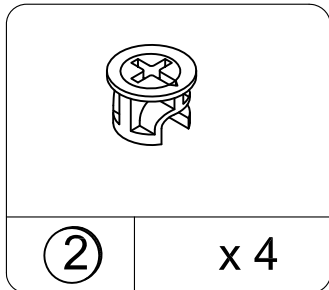

Proper orientation of cam lock
La orientación apropiada para el seguro de bloqueo
Bonne orientation du dispositif de blocage à came

9

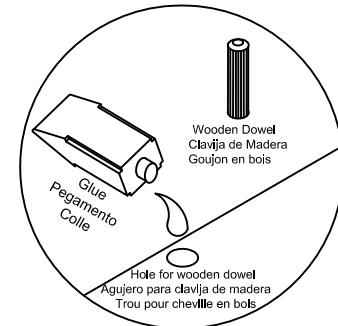
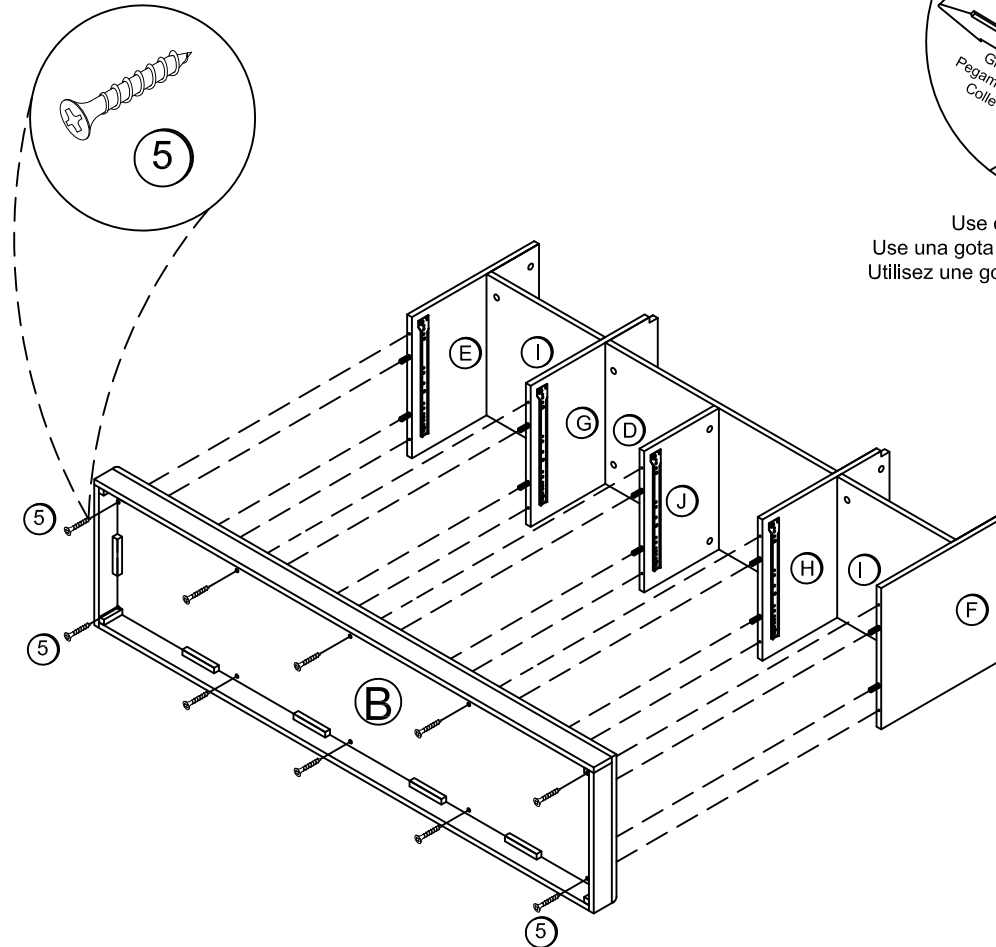

Use one drop of glue in dowel hole.
Use una gota de pegamento en el agujero de clavija.
Utilisez une goutte de colle dans le trou de la cheville

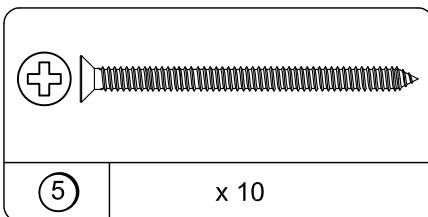

10

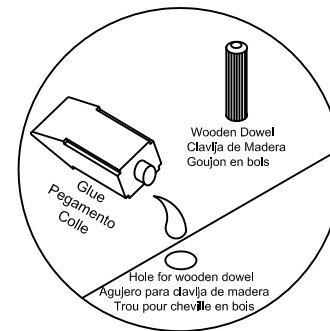

Use one drop of glue in dowel hole.
Use una gota de pegamento en el agujero de clavija.
Utilisez une goutte de colle dans le trou de la cheville

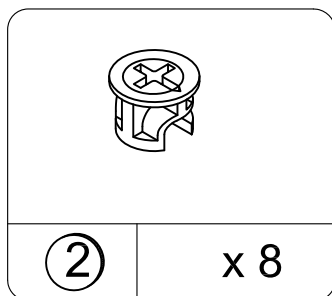
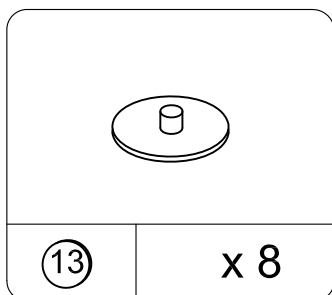
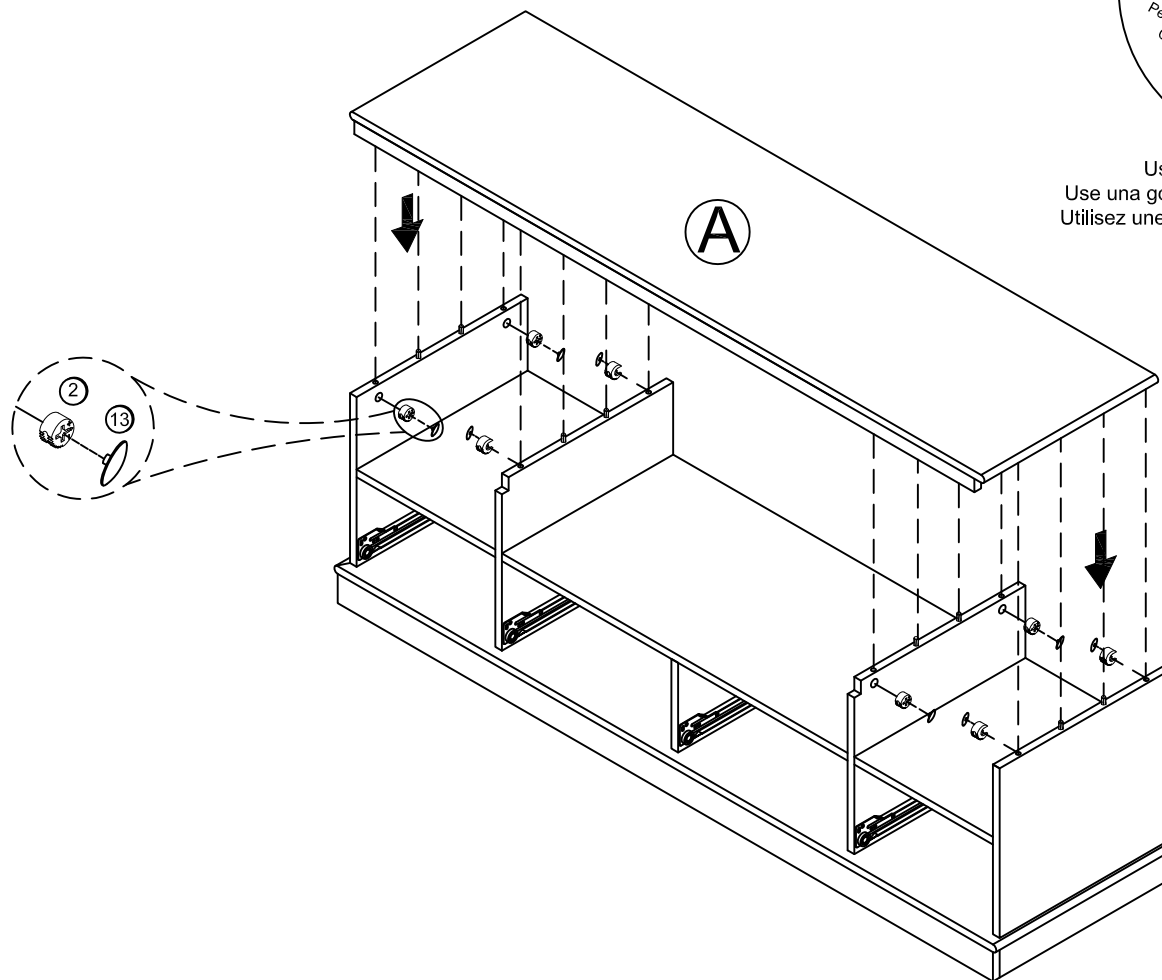

11

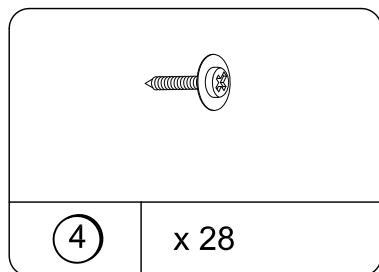
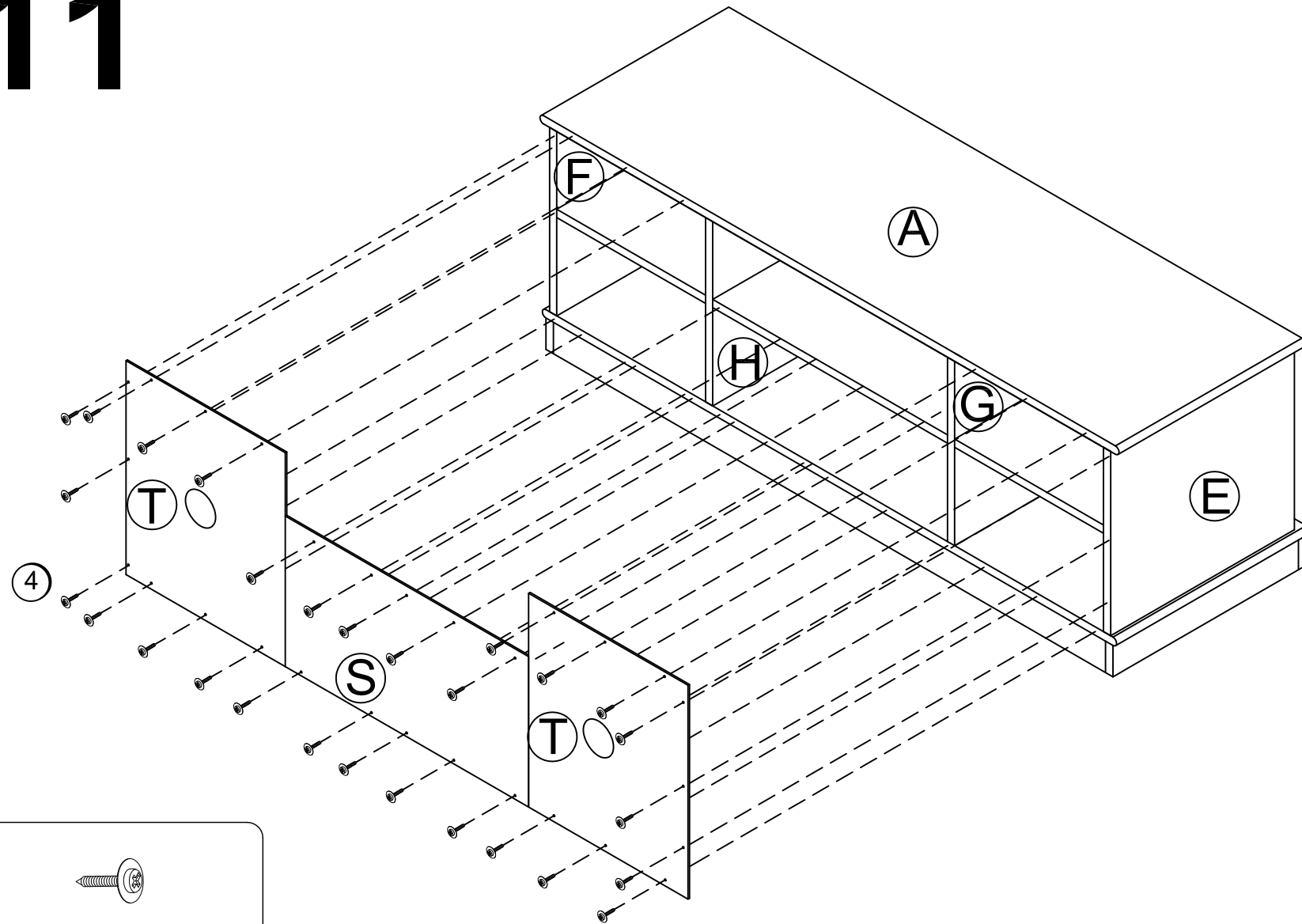

12

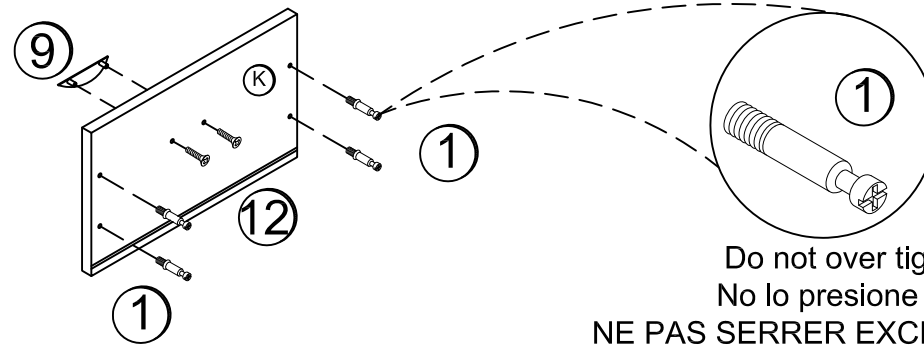
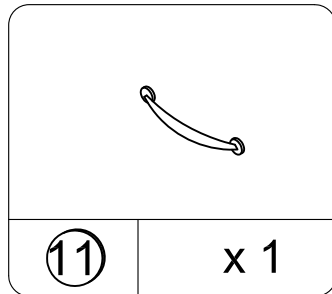
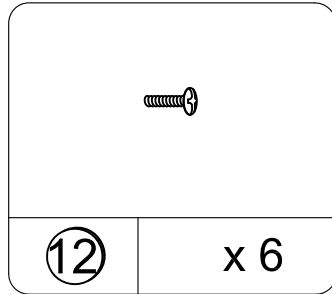
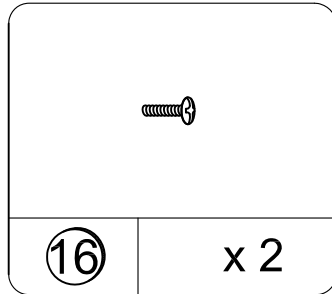
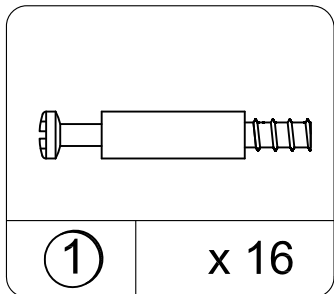
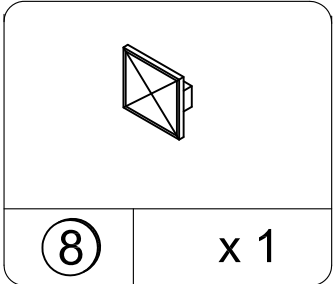
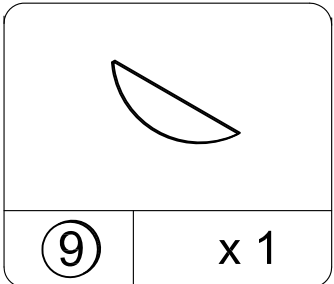
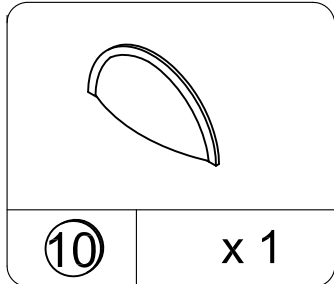

Do not over tighten.
No lo presione tanto.
NE PAS SERRER EXCESSIVEMENT.

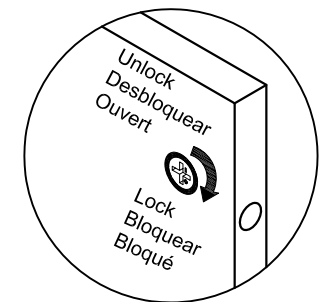
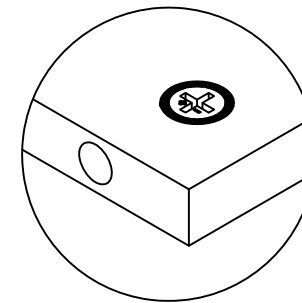
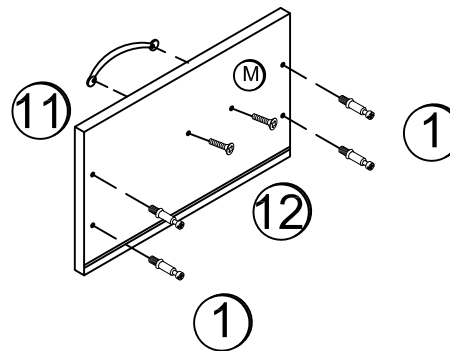
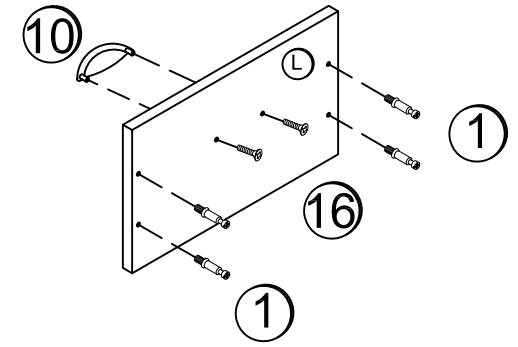
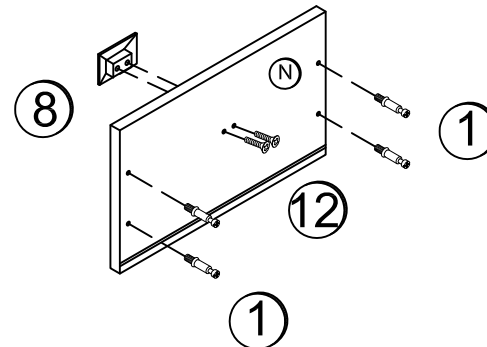

Proper orientation of cam lock
La orientacion apropiada para el seguro de bloqueo
Bonne orientation du dispositif de blocage à came

13

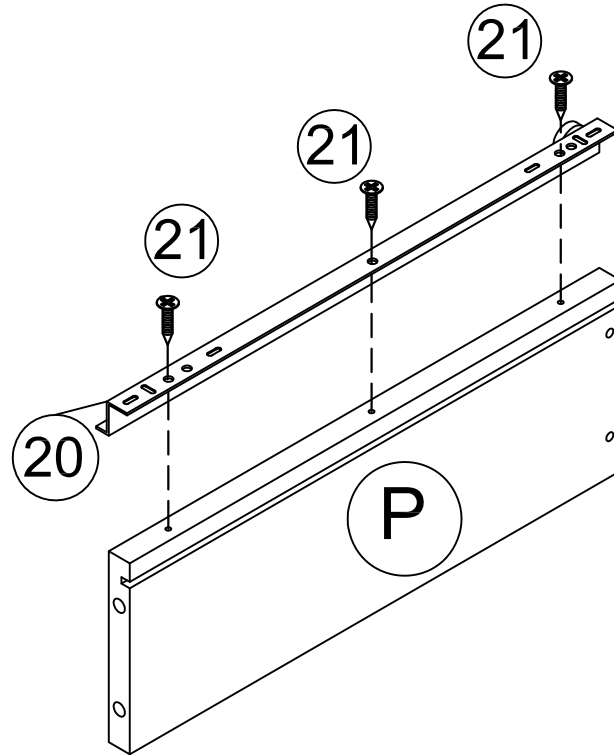

x 4

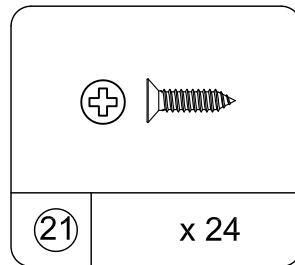
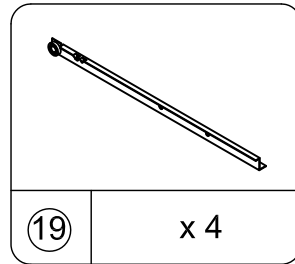
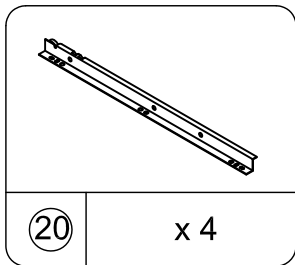
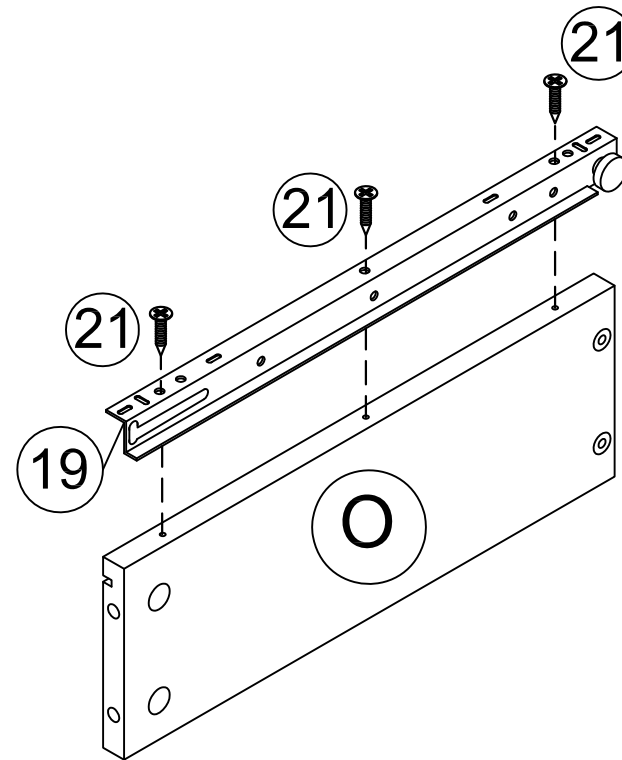

14

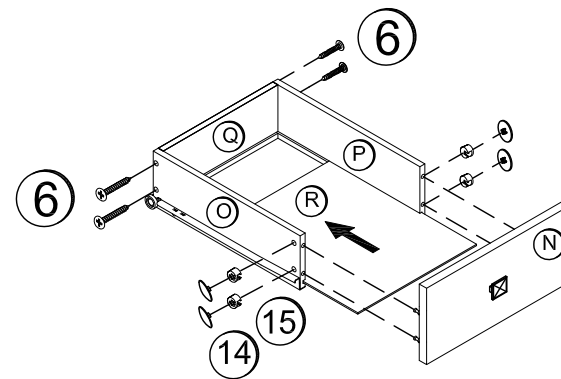
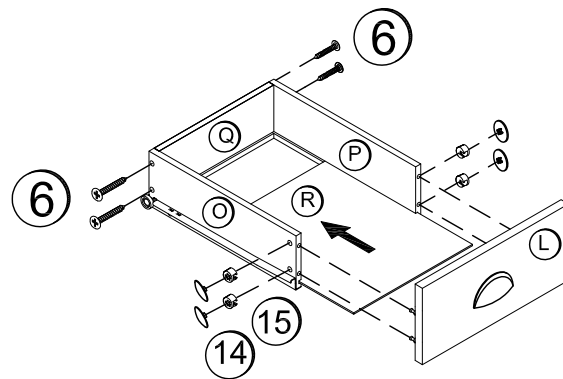
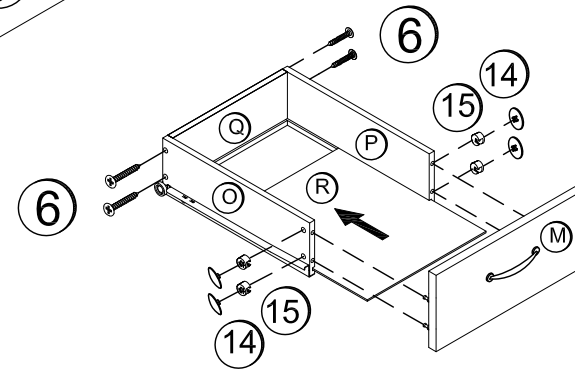
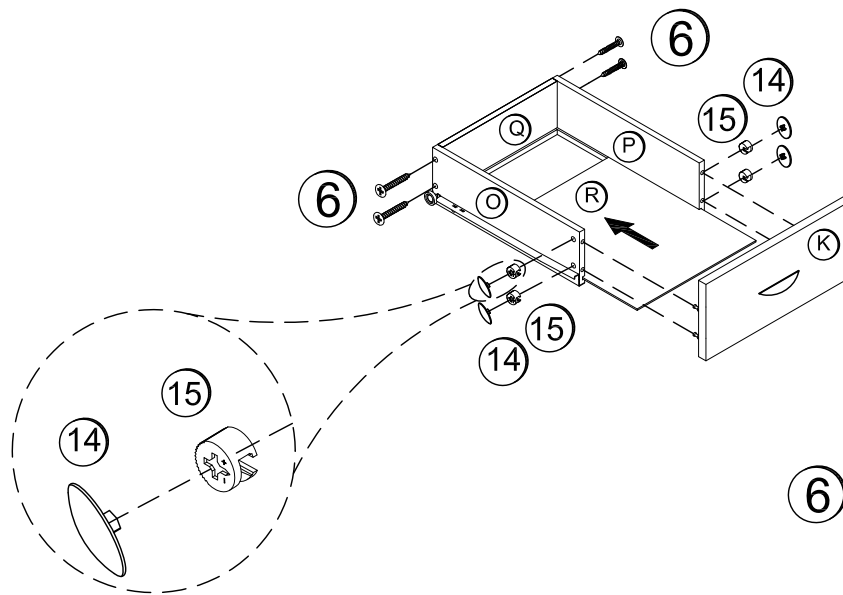
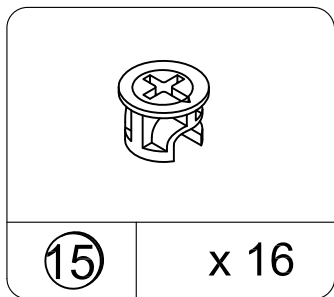
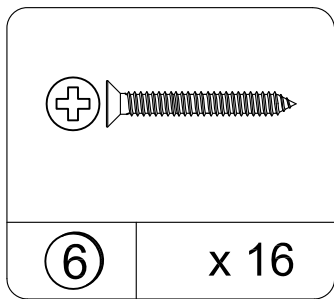
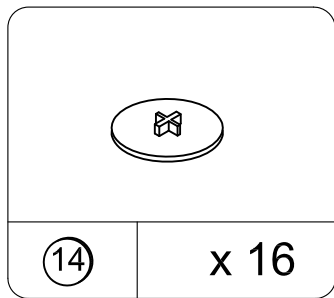

15

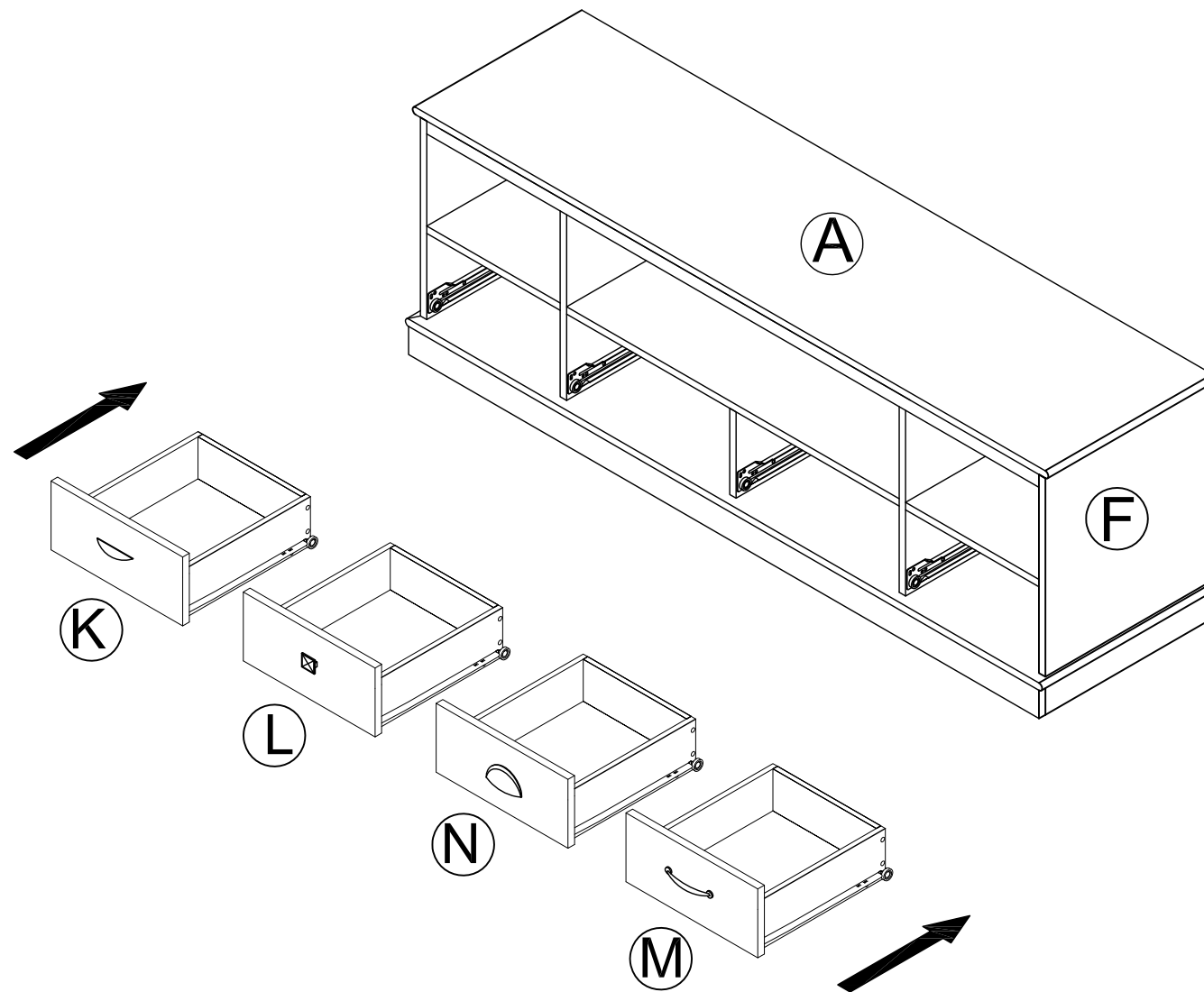

WEIGHT LIMITS:
LÍMITES DE PESO:
LIMITES DE POIDS:

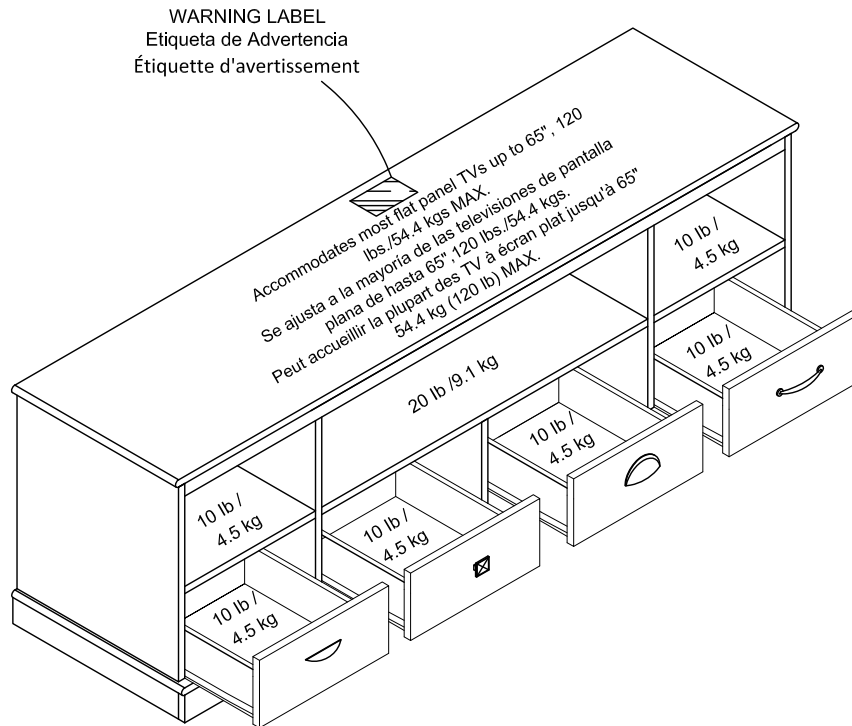

Enjoy Your Furniture
Disfrute de su mueble
Profitez de votre mobilier

This unit has been designed to support the maximum loads shown. Exceeding these load limits could cause sagging, instability, product collapse, and/or serious injury.

Esta unidad se ha diseñado para apoyar las cargas máximas mostradas. Exceder estos límites de carga podría causar ceder, inestabilidad, derrumbamiento del producto, o lesión seria.

Ce meuble a été conçu pour supporter les charges maximales indiquées. Le dépassement de ces limites de poids peut causer l'affaissement, l'instabilité, l'effondrement du produit, et/ou des blessures graves.

▲ WARNING

Please make sure that all objects are removed before moving the assembled unit.

The unit must be team lifted, not dragged or pushed.

Failure to do so could cause instability, product collapse, and/or serious injury.

▲ ADVERTENCIA

Por favor mueva el mueble cuidadosamente con la ayuda de otra persona. Levante y mueva el mueble a su lugar. No lo arrastre o empuje, de lo contrario puede haber inestabilidad en el mueble y este puede colapsar u ocasionar graves lesiones.

▲ AVERTISSEMENT

Veuillez enlever tous les objets avant de déplacer le meuble. Le meuble doit être soulevé en équipe, et non traîné ou poussé. Le non respect de cet avertissement peut provoquer l'instabilité, l'effondrement du produit, et/ou des blessures graves.